

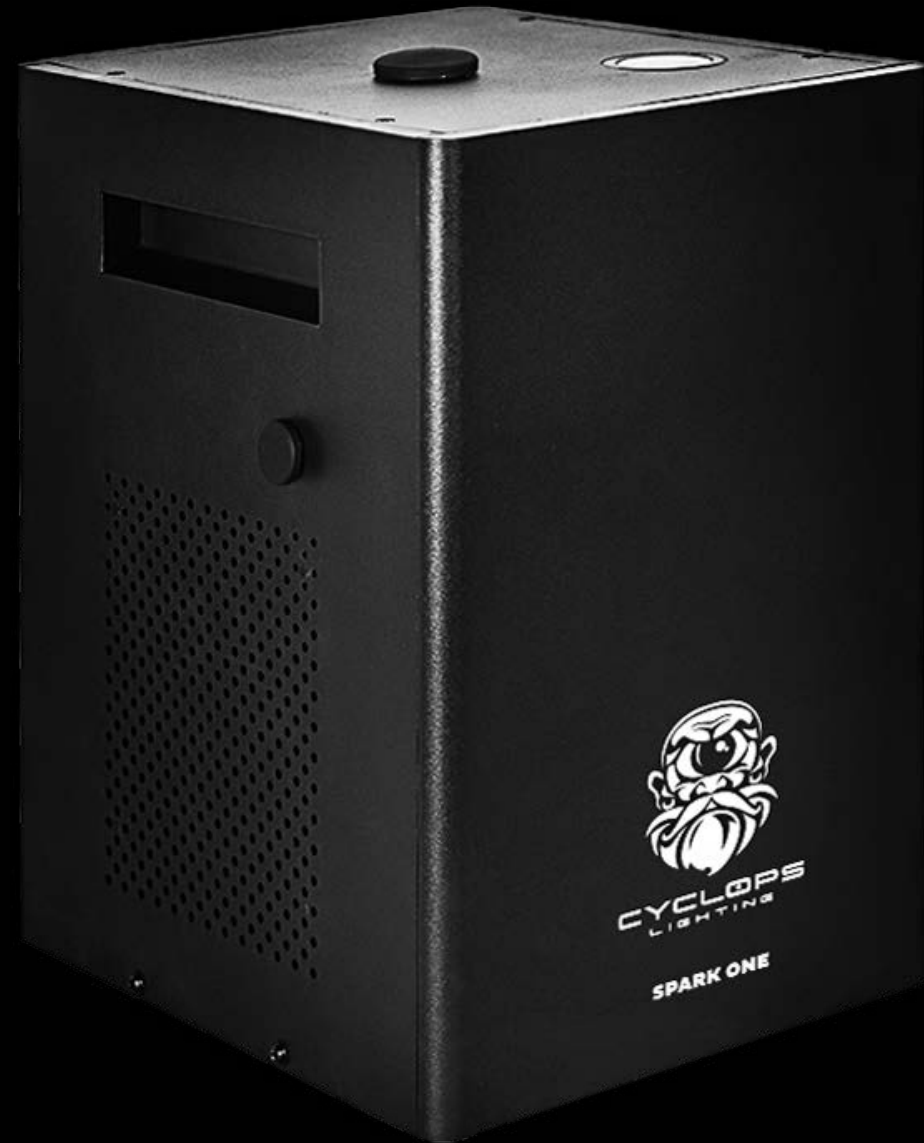

CYCLOPS
LIGHTING

SPARK ONE
DATASHEET





The **SPARK ONE** is a high-performance cold spark floor machine designed to elevate professional productions with breathtaking aerial fountain effects. Utilizing advanced electromagnetic induction heating, this fixture delivers vertical sparks reaching heights of 3 to 6 meters, with fully adjustable output to suit both intimate stages and large-scale venues. Its durable, anti-flaming ABS housing ensures maximum safety, while the internal 250g powder reservoir supports extended operation for high-impact sequences.

With support for DMX512 and a versatile wireless remote, users can easily command precision chase and build patterns or trigger a dedicated self-cleaning cycle for effortless maintenance and clog prevention. Engineered for reliability, the Spark One features PowerLink compatibility for daisy-chaining up to four units and integrated thermal protection, making it an essential tool for creating safe, dynamic, and professional-grade special effects.

CONSUMABLES

Material Type	• Titanium Alloy Granules (Outdoor Cold Spark Effect Powder – SKU: SPARKPWD)
Powder Box Capacity	• 250 g
Consumption Rate	• ~15–20 g/min (Based on output)
Effect Duration	• ~10–15 minutes per full refill

PERFORMANCE

Sparkular Height	• 3 – 6 m (Adjustable via DMX)
Fountain Direction	• Vertical Upward
Heating Method	• Electromagnetic Induction Heating
Warm-up Time	• Approx. 3–5 minutes

CONTROL & PROGRAMMING

Display	• Digital display for DMX address and temperature/status
Control Channels	• 2 CHs
Control Protocols	• DMX512 / Wireless Remote

ELECTRICAL

Input Voltage	• 110V–220V / 50Hz–60Hz
Power Consumption	• 900 W
Fuse	• 110V/12A OR 220V/6A

CONNECTIONS

DMX Connections	• 3 pin XLR In/Out male and female
Power Connections	• Powercon In/Out

PHYSICAL

Dimensions	• 220 x 250 x 310 mm
Net Weight	• 7.8 Kg
Housing	• Anti-Flaming ABS
Housing Color	• Black
Powder Box Capacity	• 250 g

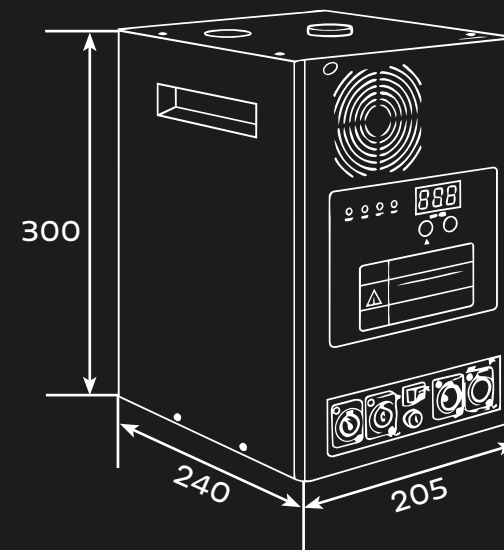



CYCLOPS
LIGHTING

www.cyclopslighting.com