

SHOT ONE

SINGLE SHOT CONFETTI & STREAMER MACHINE

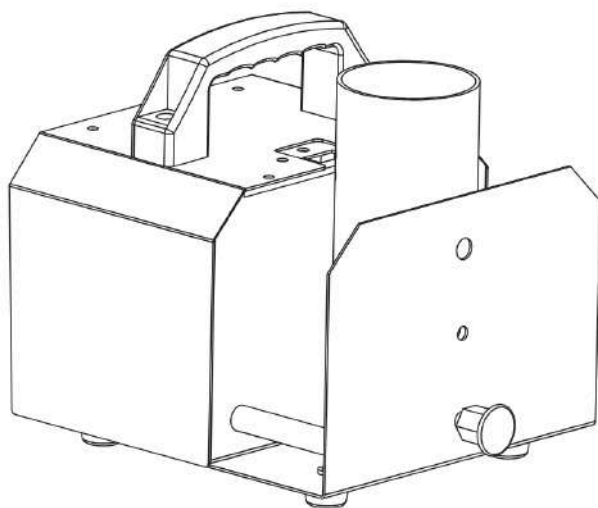

USER MANUAL



PRODUCT
DOCUMENTATION



DMX
CHART

www.cyclopslighting.com

INDEX

1. Safety Information	3
2. Safety information	4
3. Technical Specifications	5
4. Installation	5
5. Operation Steps	11
6. Maintenance	14
7. DMX Chart	15

DISCLAIMER

The product was correctly packed and certified when it left the factory. Technical specifications and features may change without prior notice. Always check the manufacturer's website for the latest manual version.



1. Introduction

1.1. Foreword

Thank you for purchasing the Shot One. This manual contains all necessary information for the safe and intended use, operation, and maintenance of the equipment. The Shot One utilizes high-pressure electric confetti cannons (e-cannons) to create aerial effects; failure to follow the instructions and warnings in this manual may result in serious injury, impact trauma, property damage, or death. This product is intended for professional use only by qualified personnel.

1.2 Liability

All users must strictly adhere to the warnings and instructions provided in this manual. Any damage or malfunction resulting from misuse, improper setup, unauthorized modification, or neglect of these operating instructions will immediately **void the warranty** and **release the manufacturer from all liability**.

We have taken considerable care to ensure this manual is correct and comprehensive; however, if you detect any errors or inaccuracies, please inform us to help improve our documentation.

2. Safety Information

The Shot One is designed to launch high-pressure electric confetti cannons (e-cannons). Failure to follow these warnings may result in serious injury or property damage.

2.1 General Safety Rules

1. **Power Disconnection:** **ALWAYS** disconnect the main power cable before cleaning, installing, or removing accessories or performing any maintenance.
2. **Environment:** **DO NOT** use this machine in rainy, humid, or outdoor environments. It is strictly forbidden to allow the machine, power plug, or cable to come into contact with water or any other liquid.
3. **No Disassembly:** If the machine malfunctions, immediately disconnect power, **DO NOT** attempt to disassemble the unit, and contact your supplier for repair.
4. **Ammunition:** This machine works **exclusively** with certified electric confetti cannons.
5. **Flammable Materials:** Keep the machine and e-cannons away from any flammable or explosive materials.

2.2 Cannon Handling and Aiming

1. **Aiming Prohibition:** **NEVER** point the electric confetti cannon output directly at people, animals, or sensitive objects/goods.
2. **Output Direction:** When installing the e-cannon, always pay attention to the outlet direction and ensure it is aimed safely, preferably upwards or away from the audience.
3. **E-Cannon Care:** Handle electric confetti cannons carefully. Do not place them under direct sunlight or near any heat source for a prolonged time.

3. Technical Specifications

Parameter	Specification
Product Name	Shot One - Single Shot Launcher
Voltage	DC12V (Requires external power supply or battery pack)
Power Consumption	40W
Control Mode	DMX512 & Remote Control
DMX Channels	5 Channels
Spray Height	6m - 12m
Net Weight	3.8 kg
Product Dimensions	22.5cm x 18.5cm x 18cm

4. Installation and Setup

4.1 Component Overview

The Shot One features a single cannon placement tube and a diagnostic LED light to confirm the cannon connection.

Component	Function
Cannon Placement Tube	Slot where the electric confetti cannon is inserted.
Cannon Lead Socket	Connects the electric firing wires from the e-cannon.

Cannon Detection Light (LED)	Green light indicates the cannon is properly installed and ready to fire.
DMX Control Panel	Digital display and buttons for setting the DMX address.
Power Input	Connection point for the DC 12V power source.

4.2 Operating Procedure

1. **DMX Setup:** Use the control panel to set the starting DMX address (e.g., 001). The DMX address light should appear once the machine is powered on.
2. **Power Supply:** Provide the machine with the required DC 12V power supply. Check that the main power indicator light is on.
3. **Secure Cannon:**
 - Ensure the machine is in the **non-triggered (safe) state** using the control panel or DMX.
 - Place the electric confetti cannon inside the placement tube and secure it using the screw knob.
 - **Crucially:** Pay attention to the outlet direction of the cannon.
4. **Connect and Verify:** Insert the lead plug of the e-cannon into the Cannon Lead Socket on the machine.
5. **Check Safety Indicator:** Immediately check the **Cannon Detection Light (LED)**. If it is **green**, the cannon is qualified and ready to use. If the light is **off**, the e-cannon may be faulty or improperly connected and must be replaced or re-seated.
6. **Operation:** Use the control panel, remote, or DMX controller to trigger the spraying action.

4.3 CONTROL PANEL AND MENU DESCRIPTION

4.3.1 Control Panel

1. Switch
2. Power socket (in and out)
3. Digital tube display
4. 3-pin signal line DMX interface



4.3.2 Menu Description



1) Key Function

MENU	Switch interface setting parameters
▲	Parameter increase
▼	Parameter reduction
ENTER	Confirm and save parameters

2) Menu selection instructions

Addr	Address code setting (1-512)
Ettl	Total number of equipment settings (1-32)
Idnu	ID number setting (1-32)
Time	Interval time setting (0-255)
Recl	Remote control code matching (0-1)

3) Address code setting

Addr represents the address code setting interface. Press Enter on this interface to enter the settings and adjust the address code (1-512)



4) Setting the total number of units

Ettl represents the total equipment number setting interface. Press Enter on this interface to enter the settings and adjust the total equipment number (0-32)



5) ID number setting

Idnu represents the ID number setting interface. Press Enter on this interface to enter the settings and adjust the device's ID number (0-32).



6) Interval time setting

Time represents the interval setting. Press Enter on this interface to enter the settings and set the interval time for each unit to light up (0-255). The value 10 is 1s.



7) Remote control code setting

Recl This interface is for remote control code setting. Press Enter on this interface to enter the settings. When the interface is 0000, the machine is in general status and there is no code setting. When the interface is set to 0001, press the remote control and the display will flash. Code matching is successful.



4.4 Remote control instructions





A: Launch all together (multiple in series)

B: From the middle to both sides
(multiple units connected in series)

C: From left to right (multiple units in series)





D: From right to left (multiple units in series)



5. Operation Steps

Step	Action		Description / Remark
1	Angle Adjustment		Pull the indexing sheath (locking pin) outward, adjust the nozzle to the required angle, and then release the indexing sheath to lock it.
2	Consumables		Insert the confetti cannon into the nozzle, press down firmly, and insert the trigger device into the machine.

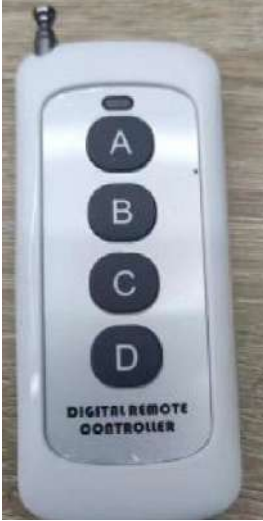
Section 4: Operation Instructions

Step	Category		Description / Remark
1	Power Selection		Plug in the power supply (110V/220V). If using multiple units, you can use the white socket to connect the power supply in series (daisy-chain).

<p>2</p>	<p>Electronic Control</p>		<p>After powering on, press the switch down to the ON position. The blue light of the machine will light up to indicate power transmission.</p>
<p>3</p>	<p>Remote Code Matching</p>		<p>(Multiple units available): Follow the pairing description in Section 7 of the manual to link remotes to specific units.</p>
<p>4</p>	<p>Remote Control</p>		<p>Use the remote control after completing the code matching. Note: You must return the display page to the main interface before the machine will respond to remote signals.</p>
<p>5</p>	<p>DMX Control (Signal)</p>		<p>Indicator ON: Small light in the lower right corner is lit = Signal is NOT connected.</p>

			<p>Indicator OFF: Small dot is NOT lit = Signal is CONNECTED.</p>
			
6	<p>DMX Addressing</p>		<p>To adjust parameters: if using 2 devices, set the total number of devices to 2. Set ID numbers to 1 and 2 in order. Adjust parameters back to the Addr interface to operate.</p>
7	<p>Shutdown</p>		<p>To end operation, turn off the power and remove the power cable and signal cables.</p>

6. Maintenance and Troubleshooting

6.1 Maintenance

In order to maximize the service life of the Shot One, it is recommended to clean, install, and disassemble accessories only when the machine is **not in use**.

- **Before servicing:** It is necessary to unplug the power plug.
- **Routine Check:** Regularly test whether the machine is working properly.
- **Danger:** Do **NOT** disassemble or replace parts on your own. If necessary, please consult your supplier for service and certified spare parts.

6.2 Troubleshooting

Problem	Possible Reason(s)	Solution
Cannon Detection Light is OFF	E-Cannon is faulty or used; poor connection; machine is disarmed.	Replace the electric confetti cannon. Check that the lead plug is fully inserted. Ensure the machine is powered.
Machine has power but will not fire	DMX value is below 11; Remote control battery is low; DMX cable issue.	Set CH1 value to 11-255. Check DMX connections. Test the machine with the remote control.
Machine is unresponsive	Incorrect DMX address is set; power supply (DC 12V) is unstable.	Check the DMX address against your controller. Verify the voltage source is stable and correct.

7. DMX Chart (5 Channel Mode)

The Shot One is designed for multi-unit serial connection. The 5 DMX channels are intended for specialized control, including triggering, safety arming, and possible special effects. Given this is a single-shot unit, Channel 1 typically manages the firing function, and the remaining channels allow for

complex triggering methods when multiple units are linked.

Channel (CH)	Value Range	Function and Description
CH1	0-10	OFF
	11-255	TRIGGER ON
CH2-5	0-255	Reserved

CORRECT DISPOSAL (WEEE)



This symbol on the product means that used electrical and electronic products (WEEE) must not be mixed with general household waste. For proper treatment, recovery, and recycling, please dispose of this product at designated collection points. Disposing of this product correctly will help save valuable resources and prevent potential negative effects on human health and the environment, which could otherwise arise from inappropriate waste handling.





CYCLOPS LIGHTING

Cyclops Lighting creates professional lighting fixtures for **lighting professionals**. Our extensive product catalog covers every lighting application, from small to big, from simple to complex. We focus on maximizing value for our users, ensuring superior **performance**, complete **documentation** and expert **worldwide support**.



www.cyclopslighting.com