

KMT12 Mark I

High tech multi-task powered 12" subwoofer with DSP and power output



DATASHEET

Features

- Unique performance-to-size ratio
- Fitted with integral handles and castors
- Direct radiating, long excursion 12" driver
- Ultra fast set-up and dismantling system
- Analog and digital AES-EBU inputs
- RS485 and USB connectivity for remote control

Applications

- Theatrical sound reinforcement
- Concert halls, clubs, houses of worship
- Portable and installed audio-visual systems
- Cinema and special effects
- Optimized for KK52, KK102 or KMT12P

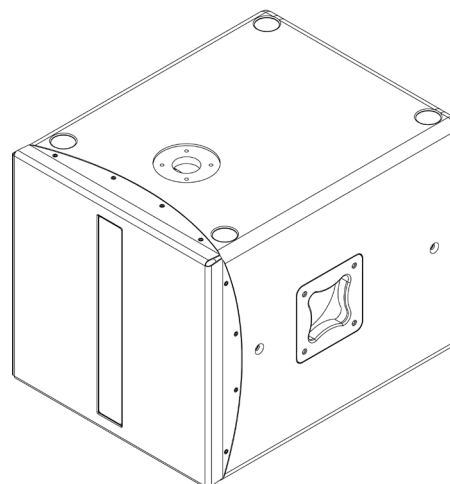

The K-array KMT12 I is a full-featured audio systems featuring a powered 12" subwoofer, programmable on-board DSP and multiple analog and digital inputs and outputs for creating a wide array of speaker configurations. The amplifier mounted on board is class D, delivering 2 x 1000 W at 8Ω.

The KMT12 I features an integrated touch screen, providing intuitive control over the main DSP functions: input/output levels, signal routing, offset delays for subwoofer and speakon output (up to 10 ms each) and overall system delay (up to 330 ms).

All DSP functions, including EQ, can also be remote controlled via software over USB or RS485 (3-pin XLR).

The KMT series provides two balanced analog line level inputs and a two-channel AES/EBU digital input. An integrated class D amplifier delivers 2 x 1000 W at 8Ω, with a max THD of 1% (EIAJ test @ 1kHz). The KMT12 I features multiple analog and digital outputs, including a Speakon output to connect a wide array of passive

speakers including mid-high modules (KK52, KK102) or additional passive subwoofers (KMT12P). To optimize performance, the on-board DSP includes presets to drive K-array speakers.

The KMT series' unique four-corner port configuration provides symmetrical back loading to the speakers, for extended bass response with very low distortion. The port configuration also provides incredible structural strength to the cabinet, despite its light weight. Pocket handles and an M20 thread mount position for attaching mid-high speakers makes the KMT series convenient to use and ideal for medium throw applications in theaters, concert halls, and Audio/Video installations.

All KMT components are designed by K-array and custom-made under K-array's quality control system.

KMT12 Mark I

Acoustics

Speaker Power handling	700 W
Max power	1200 W ¹
Impedance	8 Ω
Frequency range	45 Hz - 150 Hz ²
SPL 1W / 1mt	96 dB ³
Maximum SPL	125 dB continuous - 131 dB peak ⁴

Coverage

Omni

Crossover

Type	DSP controlled
Frequency	150 Hz (preset dependent)

Transducers

Full range	1 x 12" Neodymium speakers with 3" voice coil
------------	---

Audio Input

Analog Connectors	2 male + 2 female 3-pin balanced XLR
Digital Connectors	1 male + 1 female 3-pin XLR

Audio powered Output

Connector	Female Speakon
Wiring	Pin1+= CH1+ Pin1= CH1- Pin2+= N.C. Pin2= N.C.

Remote control Input

Connectors	1 male + 1 female XLR parallel / 1 USB B Jack serial converter
------------	--

Power Input

Connectors	2 x PowerCon IN/OUT
------------	---------------------

Amplifiers

Type	1 modules class D - DSP controlled
Subwoofer power	1000 Watt ⁵ @ 8 Ω
Speaker power output	1000 Watt ⁵ @ 8 Ω
Speaker power output	Dynamic limiter, over current, over temp, short circuits

AC power

Nominal power requirements	100 - 240 Vac \pm 10% 50-60 Hz
Operating range	85 - 265 Vac (auto-range)

Consumption

1/8 rated power (pink noise) @ 8 Ω	300 W
--	-------

Physical

Dimensions	32.6 cm x 32.7 cm x 43.3 cm (12.8" x 12.9" x 17.0")
Weight	15.6 kg (34.4 lbs)

Notes for data

1. Maximum RMS applicable power for a musical signal. The reference signal is the one proposed by EIAJ standard
2. With dedicated preset;
3. Measured @4 mt then scaled @1 mt;
4. Measured with musical signal
5. EIAJ Test Standard, 1kHz, 1%THD

New materials and design are introduced into existing products without previous notice. Present systems may differ in some respects from those presented in this catalogue.